

DESCRIPTION: FLOOR TO FLOOR FIRE BARRIER
 2 HOUR RATED UL ASSEMBLY #FF-D-0057
 NORMAL WEIGHT CONCRETE
 SUITABLE EJ COVER REQUIRED FOR LOAD BEARING APPLICATIONS
 MOVEMENT: ± 50% JOINT WIDTH
 STOCK LENGTHS: FIRE BARRIER 25'-0" ROLLS,
 METAL MOUNTING FLANGES 10'-0"

P20-FF-02

REV. 08/11



**Architectural Art
 MANUFACTURING**

Division of Pittcon Architectural Metals, LLC
 283 SWANSON DRIVE, STE 103
 LAWRENCEVILLE, GA 30043
 PH: (678) 680-7373 FAX: (678) 735-0085
 TOLL FREE: (800) 835-0028 web: www.archart.com

P Series Floor/Floor Fire Barrier

MODEL: P20-FF-02 w/PR101A-SM RETAINER

DRAWN BY:
 MB

SCALE:
 NTS

DRAWING NO.:

DTL-01

ISSUE DATE: 1/17/12

SHT. 1 OF 3

NO.	DESCRIPTION	BY	DATE

REVISIONS

The information contained herein is the proprietary property of **ARCHITECTURAL ART MFG.**, Division of Pittcon Architectural Metals, LLC. No portion of it may be reproduced by any means or used in any form except for the purpose for which it was furnished. All rights of design and invention are hereby reserved. We reserve the right to make changes in the design at our discretion.

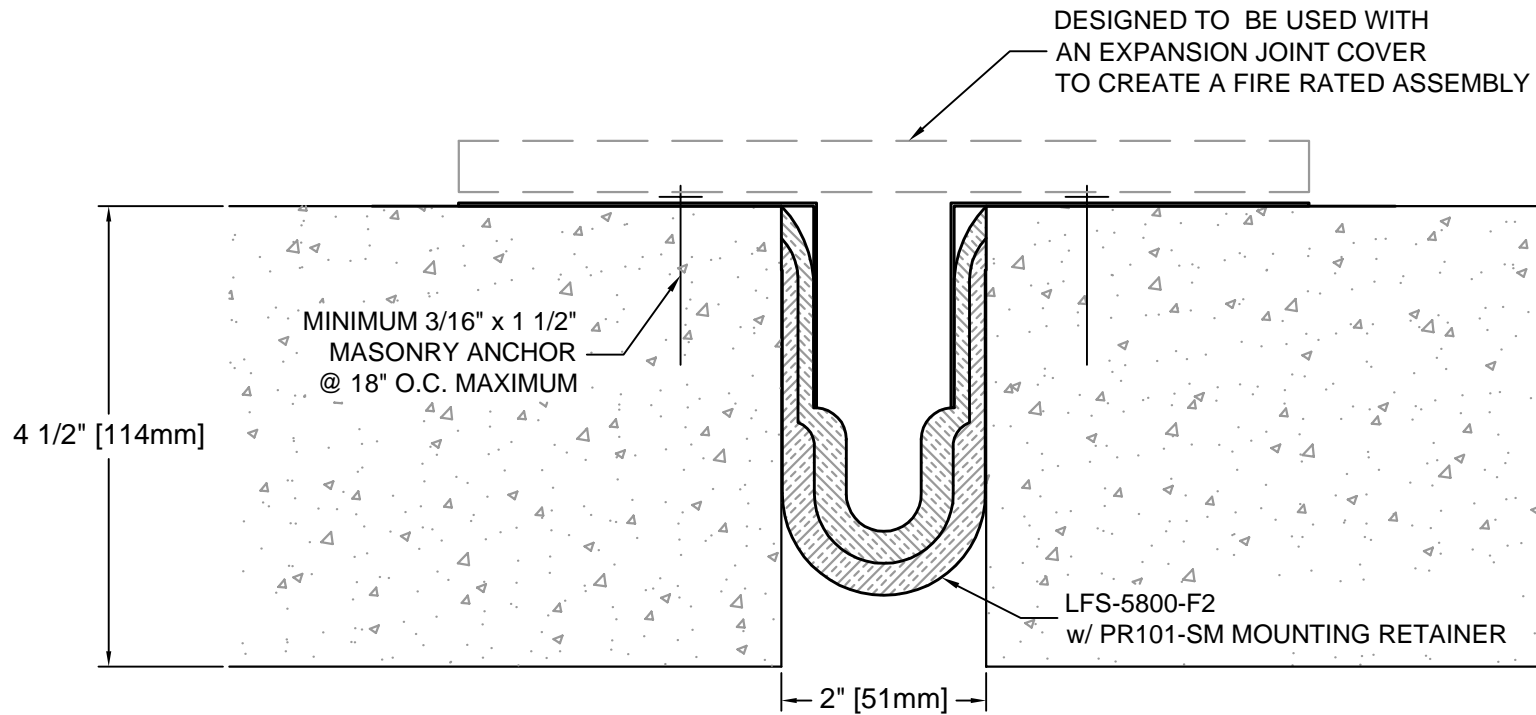

DESCRIPTION: FLOOR TO FLOOR FIRE BARRIER
 2 HOUR RATED UL ASSEMBLY #FF-D-0057
 NORMAL WEIGHT CONCRETE
 SUITABLE EJ COVER REQUIRED FOR LOAD BEARING APPLICATIONS
 MOVEMENT: ± 50% JOINT WIDTH
 STOCK LENGTHS: FIRE BARRIER 25'-0" ROLLS,
 METAL MOUNTING FLANGES 10'-0"

P20-FF-02
 REV. 08/11



**Architectural Art
 MANUFACTURING**

Division of Pittcon Architectural Metals, LLC
 283 SWANSON DRIVE, STE 103
 LAWRENCEVILLE, GA 30043
 PH: (678) 680-7373 FAX: (678) 735-0085
 TOLL FREE: (800) 835-0028 web: www.archart.com

P Series Floor/Floor Fire Barrier

MODEL: P20-FF-02 w/PR101-SM RETAINER

DRAWN BY: MB	SCALE: NTS	DRAWING NO.: DTL-02
ISSUE DATE: 1/17/12	SHT. 2 OF 3	

NO.	DESCRIPTION	BY	DATE

REVISIONS

The information contained herein is the proprietary property of **ARCHITECTURAL ART MFG.**, Division of Pittcon Architectural Metals, LLC. No portion of it may be reproduced by any means or used in any form except for the purpose for which it was furnished. All rights of design and invention are hereby reserved. We reserve the right to make changes in the design at our discretion.

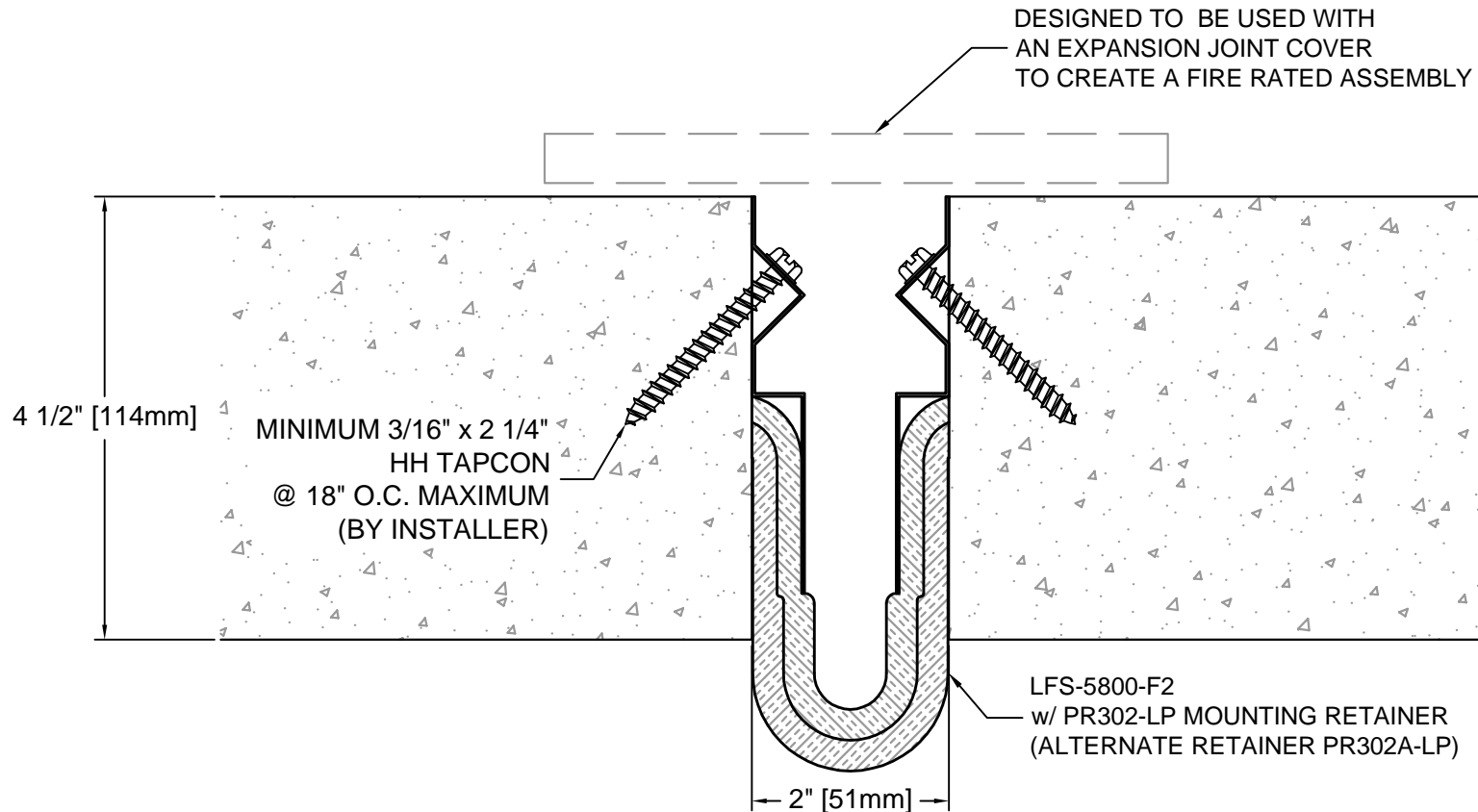

DESCRIPTION: FLOOR TO FLOOR FIRE BARRIER
 2 HOUR RATED UL ASSEMBLY #FF-D-0057
 NORMAL WEIGHT CONCRETE
 SUITABLE EJ COVER REQUIRED FOR LOAD BEARING APPLICATIONS
 MOVEMENT: ± 50% JOINT WIDTH
 STOCK LENGTHS: FIRE BARRIER 25'-0" ROLLS,
 METAL MOUNTING FLANGES 10'-0"

P20-FF-02
 REV. 038/11



**Architectural Art
 MANUFACTURING**

Division of Pittcon Architectural Metals, LLC
 283 SWANSON DRIVE, STE 103
 LAWRENCEVILLE, GA 30043
 PH: (678) 680-7373 FAX: (678) 735-0085
 TOLL FREE: (800) 835-0028 web: www.archart.com

P Series Floor/Floor Fire Barrier

MODEL: P20-FF-02 w/PR302-LP RETAINER

DRAWN BY: MB	SCALE: NTS
ISSUE DATE: 1/17/12	SHT. 3 OF 3

DRAWING NO.:
DTL-03

NO.	DESCRIPTION	BY	DATE
REVISIONS			

The information contained herein is the proprietary property of **ARCHITECTURAL ART MFG.**, Division of Pittcon Architectural Metals, LLC. No portion of it may be reproduced by any means or used in any form except for the purpose for which it was furnished. All rights of design and invention are hereby reserved. We reserve the right to make changes in the design at our discretion.