

P Fasteners

REV. 8/06

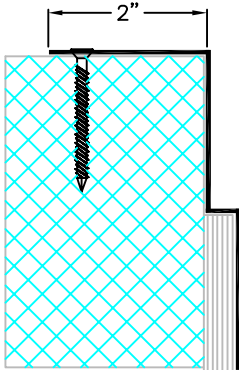

(A) (1" - 2" EJ)

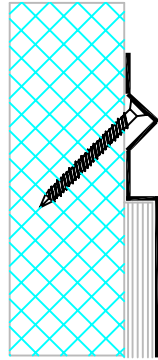

(B) (1" - 2" EJ)

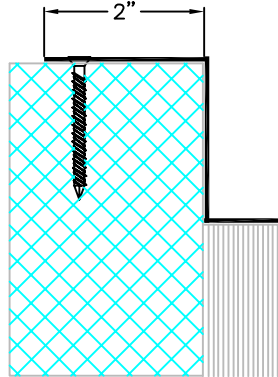

(C) (3" - 18" EJ)

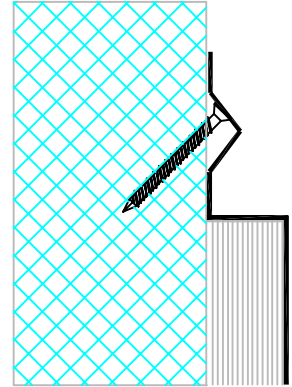

(D) (3" - 18" EJ)

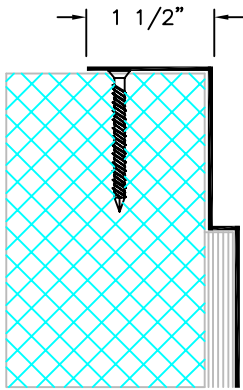

(E) (1" - 2" EJ)

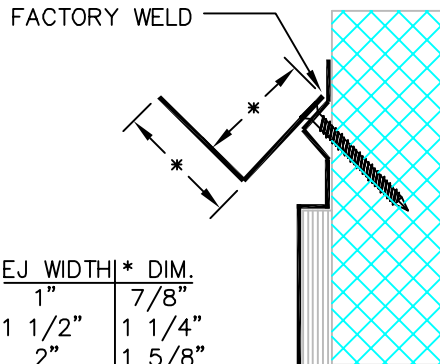

(F) (1" - 2" EJ)

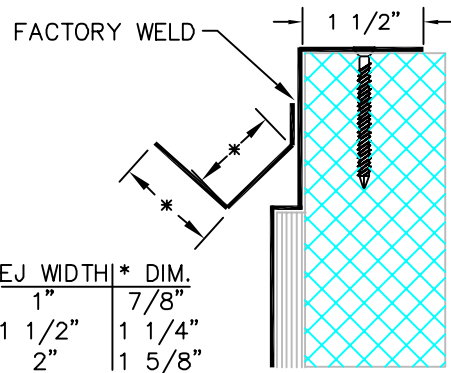

(G) (1" - 2" EJ)

FASTENERS: 3/16" x 1 3/4" F.H. TAPCON @ 1'-6" O.C.
 FLANGES: 20 GA. GALVANIZED STEEL
 EXPOSED FINISH: MILL
 STOCK LENGTHS: 10'-0"

CUSTOMER:		
PROJECT:		
LOCATION:		
ARCHITECT:		
CONTRACTOR:		
NOTE:		
JOB NO.:	DATE:	SCALE: (NTS)

LENGTH:	QTY:	COLOR/FINISH:



ARCHITECTURAL ART MFG., INC.

6409 RHODE ISLAND AVE. RIVERDALE, MD 20737

